

YELLOW DUCT.COM

FIBER OPTIC MANAGEMENT SYSTEMS

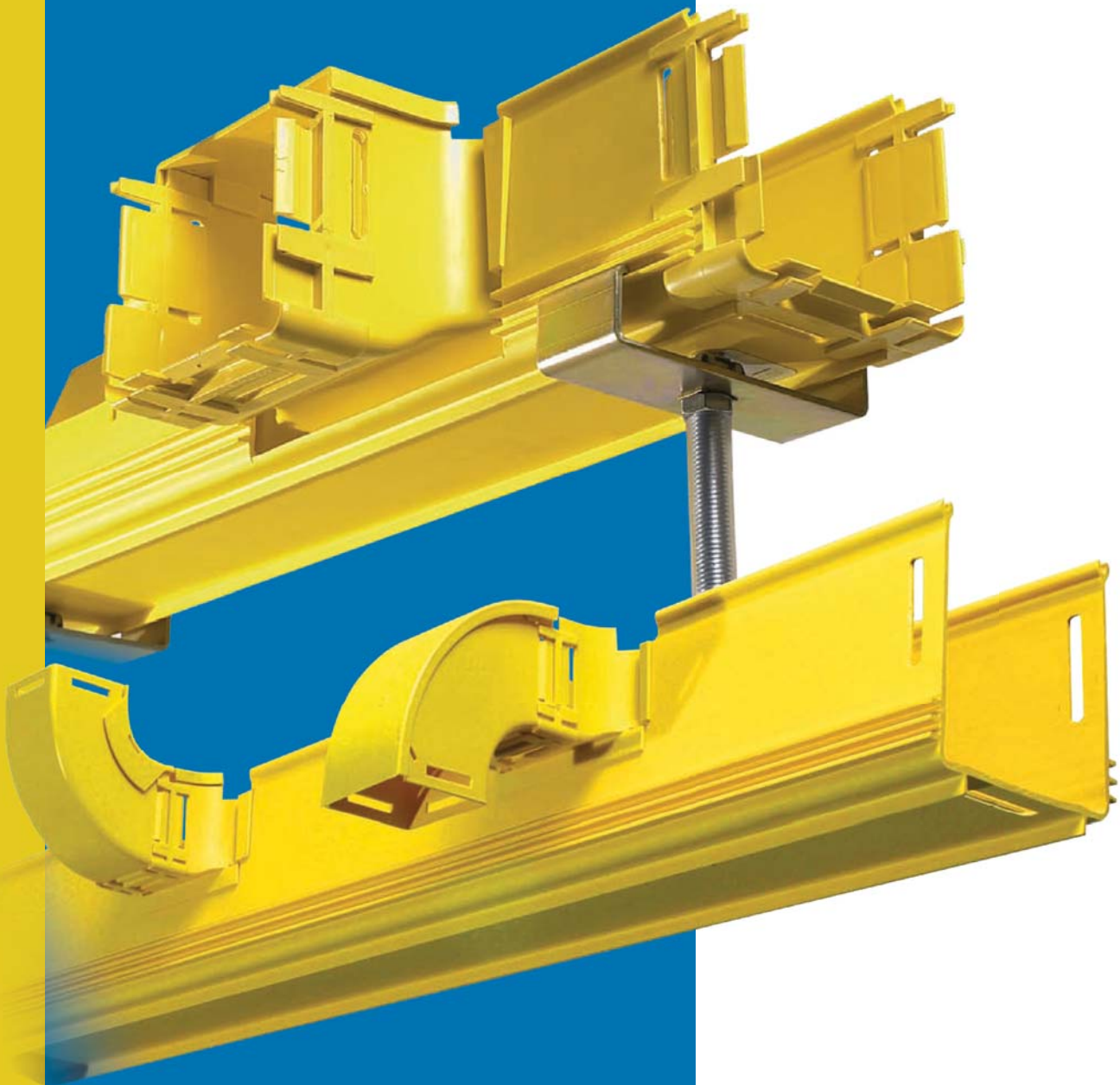

mulder-hardenberg
group

YELLOW DUCT.COM



Mulder-Hardenberg (M-H Group) is an international knowledge enterprise and leading importer and value-added distributor that creates and delivers optimum solutions in the fields of IP configured networks.

M-H Group, a private company, was established in 1927 and offers total solutions for passive infrastructure networks to its customer base that ranges from end customers to system integrators, and from R&D centers to engineering consultants and installers. M-H Group offers specialized knowledge and products in the business areas FttX, Data and Telecommunication and Industrial Automation.

M-H Group operates from offices in The Netherlands, Belgium and Germany and develops industrial products and implements Industrial Automation and Networking Projects throughout Europe and beyond.

Warren and Brown commenced manufacturing operations in Melbourne, Australia in 1921.

Over the years we have successfully designed and produced a range of products for the automotive, medical, health and fitness markets. A strong focus on developing products for global markets has provided exciting challenges and solid growth. As the company evolved and grew over the years. Warren & Brown developed a revolutionary range of innovative and highly functional products for the telecommunications industry.

The YellowDuct Fiber Optic Management System, now forms the dynamic focus of our business and Warren and Brown Technologies is recognized globally as a leading manufacturer and supplier of quality telecommunications solutions and equipment. YellowDuct products include equipment racks, splice trays and enclosures, patch panels, distribution and termination frames and plastic ducting systems for routing and protection of optical fibers.



the perfect synergy for you!

YELLOW DUCT.COM



Contents

Introduction	4-5
Designing a Lightpaths Solution	6-9
Lightpaths Components	
Ducting~Raceway System	10
Joiners	10
Elbows	11
Tees & Crosses	12
Fiber Storage	13
End Caps	13
Adaptors	13
Side Drop-off Kits	14
Drop Components	15
Reducers and Tubing	16
Plastic Mounting Brackets	17
Metal Mounting Kit	18
Suspension Kits	18
Raised Mounting Kits	19
Under Floor Kits	19
Ladder & Unistrut Kits	19
Mounting Hardware	20
Tooling	20
Tool Kit Components	21
Other Lightpaths Items	22
Lightpaths Glossary	23

Introduction

Why use fiber optic ducting-raceway

Fiber optic cords carry far more services and much greater throughput than traditional copper services and downtime or outages can cost tens of thousands of dollars per second in lost revenue for each cord damaged. Good fiber protection is absolutely essential. Fiber cords are fragile and need to be correctly protected throughout any cabling installation from end to end. Traditional cable routing on open cable trays and ladders may cause damage to the delicate fiber cables. These methods of routing cables provide no protection for the exposed fiber.

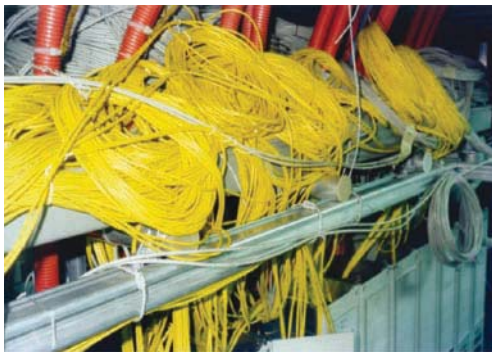

High risk, poor (spaghetti optics) cable management - or should we say lack of management

Fiber cords need to be segregated from all copper services and routed in enclosed duct~raceway, clearly defined by means of a bright distinctive colour. They also need protection against compression, and the minimum bend radius, generally specified as 30mm (1.25") must not be compromised.



Fiber optic ducting~raceway is the best way to safely route cords and clearly segregate them from other services. In selecting a ducting~raceway system for fiber optic cords many factors need to be considered.

- 1 Labour costs incurred in installing cabling infrastructure in telecommunications exchanges or data centres can be very expensive if the system chosen is not easy to install.
- 2 All plastic based products used should be self-extinguishing and halogen free to avoid the risk of harming staff, transmission equipment, rescuers or buildings in the case of a fire.
- 3 All plastic based products should be ROHS compliant
- 4 The need for zero down-time when using optical fiber. The system chosen should be easily changed or extended without the need to remove the existing fiber or shut down services.

Why use Lightpaths Fiber Optic Ducting~Raceway System



Lightpaths fiber optic ducting~raceway is a unique system for routing and protecting fiber optic cords between termination equipment, patch panels and fiber optic splicing cabinets or frames in telecommunications exchanges, data centres, universities, hospitals, or anywhere fiber optic cabling is present. Easily mounted above equipment racks or below floors, it provides an easily accessible solution to any situation.



Available in 6 sizes in solid wall or slotted wall for exiting fibers, with the largest range of connecting components and mounting hardware available, the Lightpaths ducting~raceway system provides a solution to any fiber routing application.

Lightpaths components simply snap together or can be joined with "slotless" joiners. Vertical drops can be positioned or added easily by adding a cutout in the horizontal duct~raceway with a simple to operate hand tool.

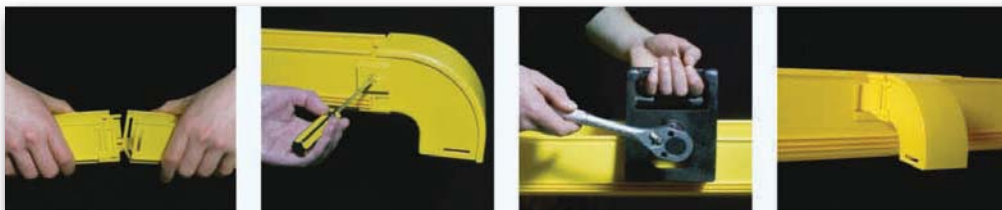

The unique design of the Lightpaths system protects the fiber from damage and ensures that the bend radius of the cable is not compromised. All components in the Lightpaths system are manufactured from Noryl, a very strong plastic, which is self extinguishing and halogen free (certified to UL94VO specification) which means in the case of a fire, the gases emitted will not cause harm to personnel, buildings or transmission equipment, unlike some other brands of ducting. Lightpaths fiber optic ducting~raceway products are manufactured to the highest quality standards (ISO9001), complying with the stringent requirements of ULA2024A & ROHS and carry a 5 year warranty.

Design & Selection procedure for Raceway System

1. Colour Coding for Optimum Cable Management

With the ever increasing demand for zero down-time solutions in data centers and Telecommunications networks there has been a growing need for redundancy cable systems.

To route both operating and redundant optic fibers in the yellow coloured ducting can create problems in identification of the redundant fiber and/or system. As a result there is an obvious need to differentiate between the operating and redundant networks of fiber optic cabling. To minimise the potential for costly mistakes in this area Warren & Brown Technologies have introduced Orange ducting which is recommended for use in highlighting the redundant fiber network and thereby improving maintenance efficiency.



Orange Ducting is recommended for highlighting the redundant fiber network



Parallel to the redundancy needs, a new issue has arisen in installations. The state-of-art 10Gigabit copper UTP cabling also has very high demands on bend radius. This requires a new approach to the conventional metal cable trays (ladders, baskets etc). The conventional metal trays are not designed to provide safe bending radius and as a result Warren & Brown Technologies has introduced the Black Ducting.

Again, this new black Lightpaths ducting has the same unique features and benefits of the yellow and orange ducting and allows clear distinction of the sensitive 10Gigabit copper UTP cabling from the two Lightpaths optic fiber systems.



Black ducting is recommended for use with UTP 10 gigabyte copper

All part numbers listed in the catalogue are for Yellow ducting so when ordering black or orange ducting just add "O" for orange or "B" for black to the end of the relevant part number. We also have available a range of grey duct. For this just add "G" to the part number.

Designing a Lightpaths solution

2. Selecting the Ducting - Raceway size

Lightpaths ducting~raceway is available in six sizes and it is most important to select a size that allows for expansion and future additions to the ducting system.

All too often cable systems are underspecified in order to reduce installation costs. In this world of the ever increasing need for the storage and processing of data it is false economy to just specify for existing needs. It is ultimately most cost effective to provide for the future and over specify when it comes to capacity.

Cable exit points and take offs also need to be taken into account as these components have different capacity ratings to the main ducting~raceway.

The capacities listed below are recommended to ensure no damage will occur to the cords due to crushing. This is not the number of optical fiber cords that the ducting~raceway will accomodate if completely filled.

Duct size millimetres / mm	30 x 30			50 x 50			100 x 50			100 x 100			220 x 100			300 x 100		
Duct size inches / in	1.25 x 1.25			2 x 2			4 x 2			4 x 4			8 x 4			12 x 4		
Optical cable size / mm	3	2-2.4	1.6-2	3	2-2.4	1.6-2	3	2-2.4	1.6-2	3	2-2.4	1.6-2	3	2-2.4	1.6-2	3	2-2.4	1.6-2
Capacities																		
Straight Duct~Raceway	45	55	90	120	145	240	280	350	570	500	630	1000	1100	1400	1650	1500	2100	3400
Duct~Raceway with ramp-off										300	370	600	720	920	1490			
Vertical Tee Downspout										500	630	1000						
Vertical Tee Downspout Over the top outlet	Type TC 1279-11 A or R						(Downward)			300	370	600	(500	630	1000	Straight on)		
Convolutated tubing																		
	Split 20mm dia.			38mm dia.			50mm dia.			50 x 50 Square								
Optical cable size / mm	3	2-2.4	1.6-2	3	2-2.4	1.6-2	3	2-2.4	1.6-2	3	2-2.4	1.6-2						
Tubing Capacities	10	20	12	24	28	45	60	75	120	120	145	240						

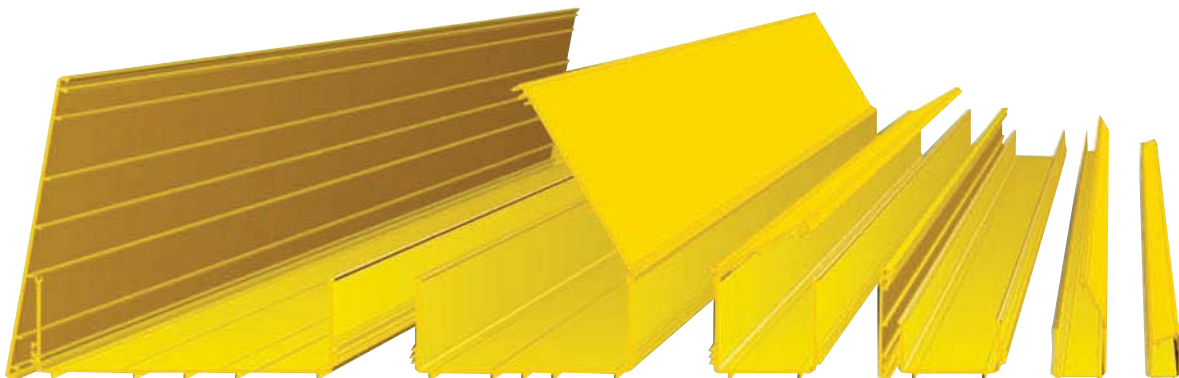

3. Ducting - Raceway mounting

3.A - Metal Mountings

Lightpaths ducting~raceway can be mounted from walls, ladder rack, unistrut, on raised floor support brackets, on floors, or to the top of equipment racks of frames. Select an appropriate mounting method from the examples shown below otherwise you can contact your Lightpaths sales office or distributor for other mounting options and custom solutions.

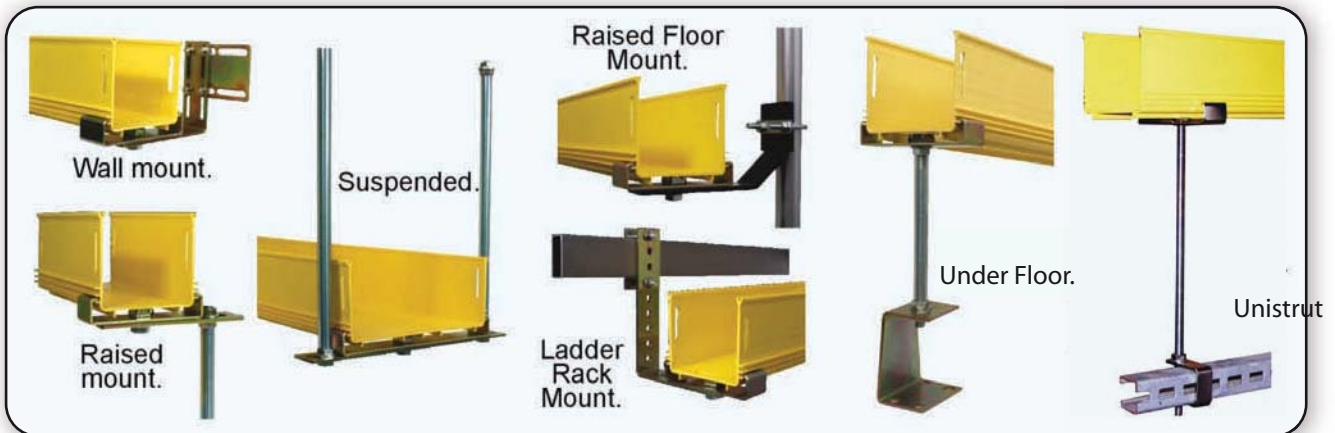

3.B- Plastic Mountings

A new, strong but lightweight plastic mounting bracket system is now available with an efficient one-suits-all approach. The one system of plastic brackets can accommodate all sizes of ducting from 50mm to 300 mm. This revolutionary approach to ducting mounting allows for a large variety of configurations and eliminates the need for C brackets. A further benefit of the plastic bracket is that it is available in all the same colours as Lightpaths Ducting - yellow, orange, black and grey.

Suspension Mounting

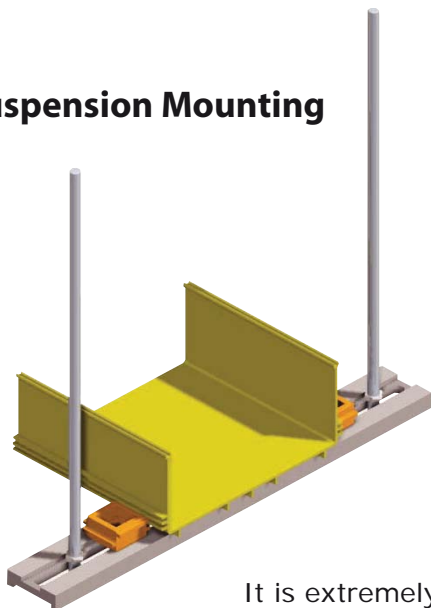

Wall Mount or Ladder Mount

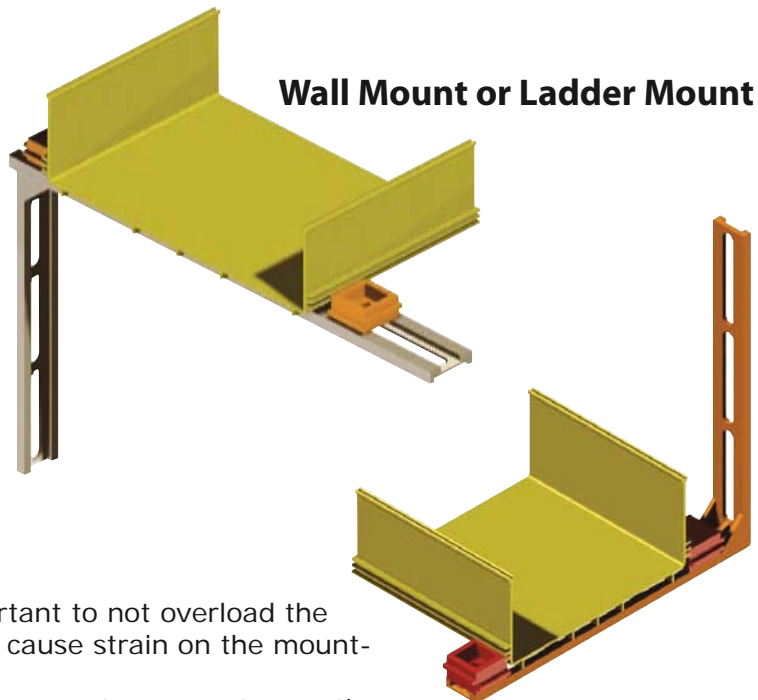

It is extremely important to not overload the ducting, as this may cause strain on the mounting.
It is always better to use extra support mounting than trying to cut costs by increasing the bracket distance.

4. Cable entry and exits

Select the appropriate dropper or outlet method from the following examples.



Round convoluted tube

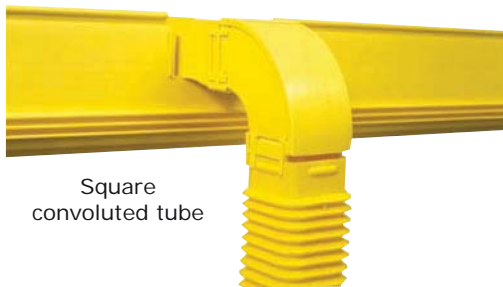

Square convoluted tube



Solid Duct



Trumpet

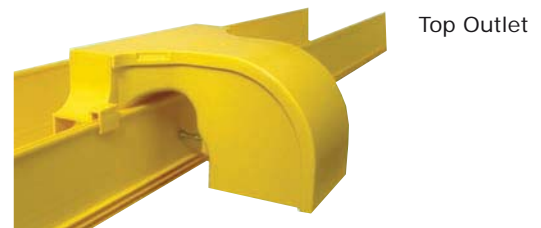

Top Outlet

5. Draw plan

Draw plan view of room/area where ducting~raceway is required. Include cabinet sizes and positions as well as ladder racks, cable trays or Air conditioning ducts.

Denote duct size required in each area. Mark ducting~raceway support bracket locations. The recommended spacing for mounting brackets is 900mm or 1.2 Metres maximum.

For copper systems use 600mm spacing. Brackets should be mounted close to the joiners if possible. Draw a side view of all areas where the ducting~ raceway changes level.

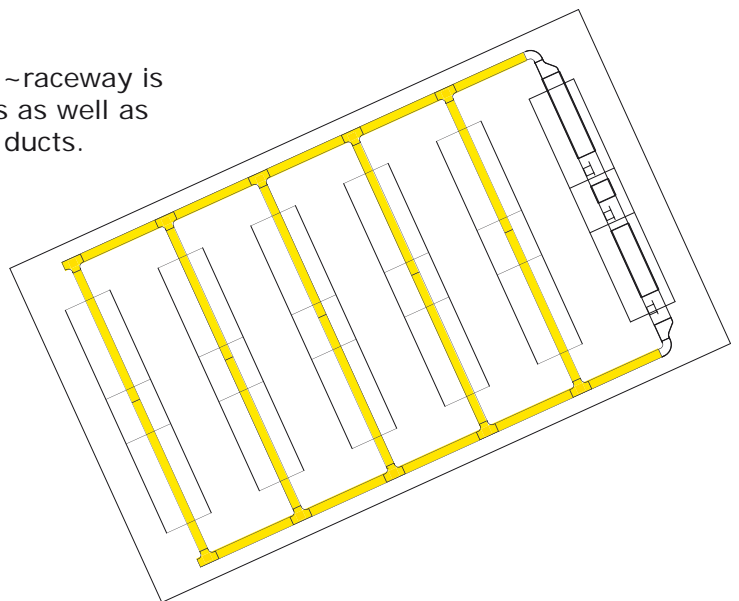

6. Materials List

List all components required by part number and quantity from the following pages. Note: Ensure that all components including joiners, mounting hardware, end caps, convoluted tube etc. are included.

We recommend including 10% more joiners and brackets.

Straight Ducting - Raceway

Lightpaths straight ducting~raceway is available in six sizes with or without covers. Slotted duct/raceway is available in some sizes for vertical drops or applications inside equipment racks to allow cords to exit through the side of the duct. Some sizes are available with hinged covers (hinges included in pack), or clip on covers. All duct sizes come in 2Metre (6.5') lengths, and where required, are slotted at each end for simply snapping together with an appropriate joiner. Most other ducting - raceway brands are only available in 6 foot lengths - 10% shorter than Lightpaths.

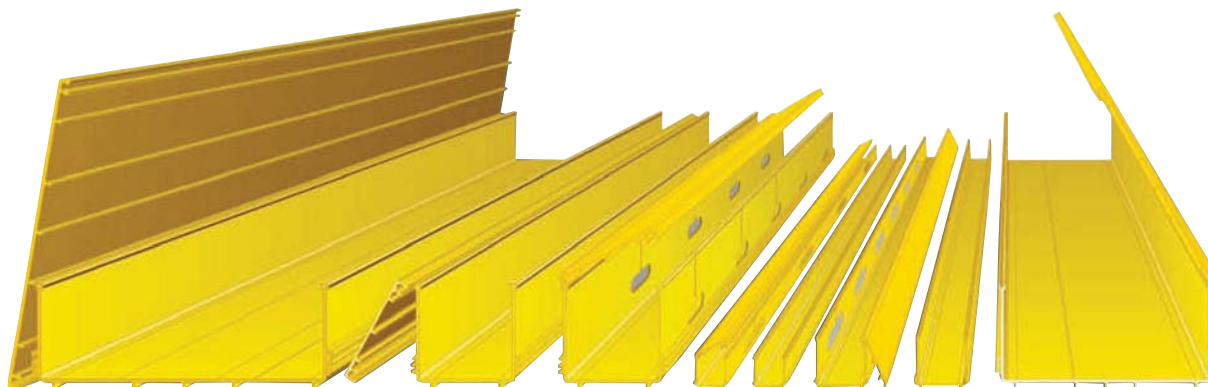

Size Millimetres Size Inches	30 x 30 1.25" x 1.25"	50 x 50 2" x 2"	100 x 50 4" x 2"	100 x 100 4" x 4"	220 x 100 8" x 4"	300 x 100 12" x 4"
Solid duct	TC1279-83	TC1279-81	TC1279-223	TC1279-23	TC1279-21	TC1279-275
Solid duct & cover	TC1279-83XA	TC1279-81XA	TC1279-223ASN	TC1279-23ASN	TC1279-21ASN	TC1279-275A
Solid duct & hinged cover	TC1279-83A*	TC1279-81A*	TC1279-223A	TC1279-23A	TC1279-21A	N/A
Slotted duct (side exit)	TC1279-83SL	TC1279-81SL	TC1279-223SL	TC1279-23SL	N/A	N/A
Slotted duct & cover	TC1279-83SLXA	TC1279-81SLXA	TC1279-223SLASN	TC1279-23SLASN	N/A	N/A
Slotted duct & hinged cover	TC1279-83SLA*	TC1279-81SLA*	TC1279-223SLXA	TC1279-23SLA	N/A	N/A

* comes with 8 shorter clip on covers

Joiners

Lightpaths joiners are used to snap together system components and straight ducting~raceway. They simply snap into the slots in the end of each piece to be joined. Note: For straight ducting~raceway that has been cut to length, new slots need to be made with a suitable size slotting tool.

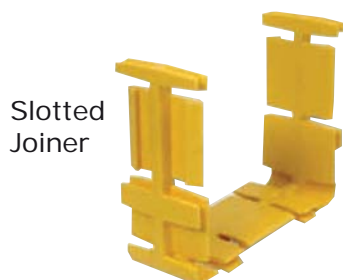

"Slotless" joiners are now available in sizes from 100 x 100mm upwards and will join the ducting~raceway components with or without joining slots.

Size Millimetres Size Inches	30 x 30 1.25" x 1.25"	50 x 50 2" x 2"	100 x 50 4" x 2"	100 x 100 4" x 4"	220 x 100 8" x 4"	300 x 100 12" x 4"
Joiners (requires slots)	TC1279-98	TC1279-73	TC1279-226	TC1279-27	TC1279-25	TC1279-320KIT
Slotless Joiners	N/A	N/A	N/A	TC1279-248A	TC1279-250A	TC1279-287A

Vertical Elbows

Lightpaths vertical elbows are used to connect horizontal routes at different height, or to allow the fiber path to be raised or lowered to avoid obstacles. Retrofit versions are used where there is existing fiber. They are available with or without covers.



Size Millimetres Size Inches	30 x 30 1.25" x 1.25"	50 x 50 2" x 2"	100 x 50 4" x 2"	100 x 100 4" x 4"	220 x 100 8" x 4"	300 x 100 12" x 4"
30° down	TC1279-135-30	TC1279-87-30	N/A	TC1279-111-30	TC1279-123-30	N/A
30° down & cover	TC1279-135-30A	TC1279-87-30A	N/A	TC1279-111-30A	TC1279-123-30A	N/A
30° down retrofit	N/A	N/A	N/A	TC1279-111-30R	TC1279-123-30R	N/A
30° up	N/A	N/A	N/A	TC1279-113-30	TC1279-125-30	N/A
30° up & cover	N/A	N/A	N/A	TC1279-113-30A	TC1279-125-30A	N/A
30° up retrofit	N/A	N/A	N/A	TC1279-113-30R	TC1279-125-30R	N/A
45° down	TC1279-135-45	TC1279-87-45	N/A	TC1279-111-45	TC1279-123-45	TC1279-285
45° down & cover	TC1279-135-45A	TC1279-87-45A	N/A	TC1279-111-45A	TC1279-123-45A	TC1279-285A
45° down retrofit	N/A	N/A	N/A	TC1279-111-45R	TC1279-123-45R	N/A
45° up	N/A	TC1279-143-45	N/A	TC1279-113-45	TC1279-125-45	TC1279-283
45° up & cover	N/A	TC1279-143-45A	N/A	TC1279-113-45A	TC1279-125-45A	TC1279-283A
45° up retrofit	N/A	TC1279-143-45R	N/A	TC1279-113-45R	TC1279-125-45R	N/A
90° down	TC1279-135	TC1279-87	TC1279-236	TC1279-111	TC1279-123	TC1279-193
90° down & cover	TC1279-135A	TC1279-87A	TC1279-236A	TC1279-111A	TC1279-123A	TC1279-193A
90° down retrofit	N/A	TC1279-87R	TC1279-236R	TC1279-111R	TC1279-123R	N/A
90° up	TC1279-247	TC1279-143	TC1279-246	TC1279-113	TC1279-125	TC1279-298A
90° up & cover	TC1279-247A	TC1279-143A	TC1279-246A	TC1279-113A	TC1279-125A	TC1279-298KIT
90° up retrofit	TC1279-247R	TC1279-143R	TC1279-246R	TC1279-113R	TC1279-125R	N/A
90° up & down enclosed	N/A	N/A	N/A	TC1279-39A	TC1279-37A	N/A

Horizontal Elbows

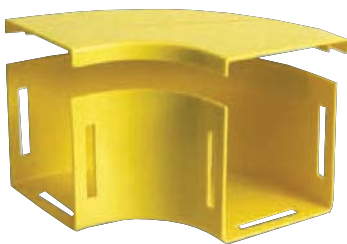

Lightpaths Horizontal Elbows are used to change the direction of horizontal routes. They are available with or without covers.



Size Millimetres Size Inches	30 x 30 1.25" x 1.25"	50 x 50 2" x 2"	100 x 50 4" x 2"	100 x 100 4" x 4"	220 x 100 8" x 4"	300 x 100 12" x 4"
30° elbow	TC1279-137-30	TC1279-77-30	N/A	TC1279-47	TC1279-45	N/A
30° elbow & cover	TC1279-137-30A	TC1279-77-30A	N/A	TC1279-47A	TC1279-45A	N/A
45° elbow	TC1279-137-45	TC1279-77-45	N/A	TC1279-31-45	TC1279-29-45	TC1279-304
45° elbow & cover	TC1279-137-45A	TC1279-77-45A	N/A	TC1279-31-45A	TC1279-29-45A	TC1279-304A
90° elbow	TC1279-137	TC1279-77	TC1279-269	TC1279-31	TC1279-29	TC1279-304KIT
90° elbow & cover	TC1279-137A	TC1279-77A	TC1279-269A	TC1279-31A	TC1279-29A	TC1279-304AKIT

Horizontal Tees

Lightpaths Horizontal Tees may be used to branch off the main route or provide a method of breaking into Horizontal Duct. They are available with or without covers.



Size Millimetres Size Inches	30 x 30 1.25" x 1.25"	50 x 50 2" x 2"	100 x 50 4" x 2"	100 x 100 4" x 4"	220 x 100 8" x 4"	300 x 100 12" x 4"
Horizontal Tee	TC1279-115	TC1279-75	TC1279-224	TC1279-03	TC1279-01	TC1279-279
Horizontal Tee & Cover	TC1279-115A	TC1279-75A	TC1279-224A	TC1279-03A	TC1279-01A	TC1279-279A
300mm - 220mm Duct Horizontal Tee & Cover	TC1279-316A		220mm - 100mm Duct Horizontal Tee & Cover TC1279-09A			

Vertical Tees (Downspouts)

Lightpaths Vertical Tees can be used to drop cables vertically from horizontal routes into frames or cabinets. Retro tees provide open access and are used where cables are already in place. They are available with or without covers.

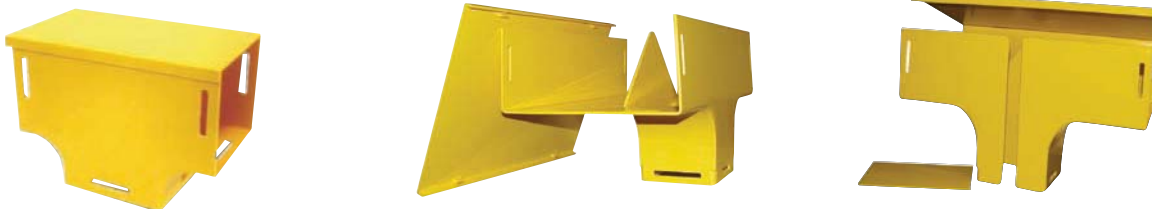

Size Millimetres Size Inches	30 x 30 1.25" x 1.25"	50 x 50 2" x 2"	100 x 50 4" x 2"	100 x 100 4" x 4"	220 x 100 8" x 4"	300 x 100 12" x 4"
30 x 30mm drop	TC1279-167	N/A	N/A	N/A	N/A	N/A
30 x 30mm drop & cover	TC1279-167A	N/A	N/A	N/A	N/A	N/A
50 x 50mm drop	N/A	TC1279-145	N/A	N/A	N/A	N/A
50 x 50mm drop & cover	N/A	TC1279-145A	N/A	N/A	N/A	N/A
50 x 50mm drop retro	N/A	TC1279-145R	N/A	N/A	N/A	N/A
100 x 50mm drop	N/A	N/A	TC1279-228	N/A	N/A	N/A
100 x 50mm drop & cover	N/A	N/A	TC1279-228A	N/A	N/A	N/A
100 x 100mm drop	N/A	N/A	N/A	TC1279-63	TC1279-11	N/A
100 x 100mm drop & cover	N/A	N/A	N/A	TC1279-63A	TC1279-11A	N/A
100 x 100mm drop retro	N/A	N/A	N/A	TC1279-63R	TC1279-11R	N/A
220 x 100mm drop	N/A	N/A	N/A	N/A	N/A	TC1279-277
220 x 100mm drop & cover	N/A	N/A	N/A	N/A	TC1279-329A	TC1279-277A

Horizontal Crosses

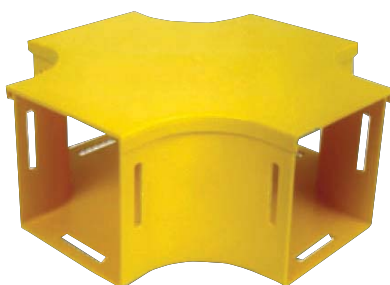

Lightpaths Horizontal Crosses can be used to provide a cross intersection in straight duct. Reduction crosses join horizontal duct of different sizes.

Size Millimetres Size Inches	30 x 30 1.25" x 1.25"	50 x 50 2" x 2"	100 x 50 4" x 2"	100 x 100 4" x 4"	220 x 100 8" x 4"	300 x 100 12" x 4"
Horizontal Cross	N/A	TC1279-139	TC1279-234	TC1279-71	TC1279-61	TC1279-300
Horizontal Cross & cover	N/A	TC1279-139A	TC1279-234A	TC1279-71A	TC1279-61A	TC1279-300A
Reduction Cross	220 x 100 to 100 x 100		Part No. TC1279-65		220 x 100 to 300 x 100	
Reduction Cross & Cover	220 x 100 to 100 x 100		Part No. TC1279-65A		220 x 100 to 300 x 100	
					Part No. TC1279-331	
					Part No. TC1279-331A	

Fiber Storage Loops

Lightpaths Fiber Storage Loops are used to safely store excess fiber length and can be placed in any horizontal route or inside cabinets. They are available in inline or offset versions.

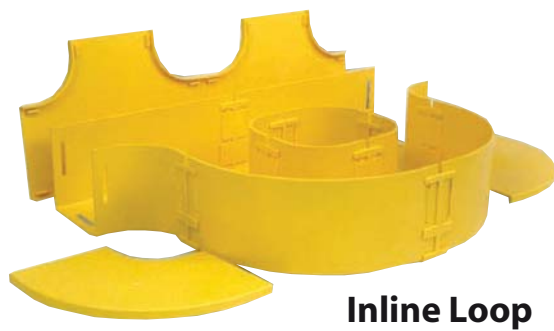

Inline Loop



Offset Loop

Size Millimetres Size Inches	30 x 30 1.25" x 1.25"	50 x 50 2" x 2"	100 x 50 4" x 2"	100 x 100 4" x 4"	220 x 100 8" x 4"	300 x 100 12" x 4"
Inline	N/A	TC1279-209KIT	TC1279-186KIT	TC1279-208KIT	TC1279-207KIT	N/A
Offset	N/A	TC1279-178KIT	TC1279-195KIT	TC1279-192KIT	TC1279-191KIT	TC1279-315KIT

End Caps

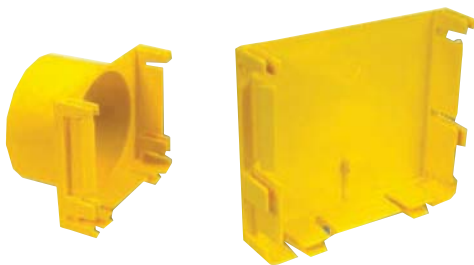

Lightpaths End Caps are used to close off the end of a horizontal or vertical route of duct. Some are sealed, others have knock outs or spigots for convoluted tubing or fiber feedout.

Size Millimetres Size Inches	30 x 30 1.25" x 1.25"	50 x 50 2" x 2"	100 x 50 4" x 2"	100 x 100 4" x 4"	220 x 100 8" x 4"	300 x 100 12" x 4"
Sealed	N/A	N/A	TC1279-227	TC1279-57	TC1279-56	N/A
Sealed	N/A	N/A	N/A	TC1279-51	TC1279-252	TC1279-288
(for use with slotless duct)			N/A		N/A	N/A
1 x 17mm knockout	TC1279-128	N/A	N/A	N/A	N/A	N/A
Tube outlet for 32mm tube	TC1279-128D	N/A	N/A	N/A	N/A	N/A
2 x 20mm dia knockouts	N/A	TC1279-127	N/A	N/A	N/A	N/A
1 x 38mm dia knockout	N/A	TC1279-127B	N/A	N/A	N/A	N/A
1 x 38mm hole	N/A	TC1279-127C	N/A	N/A	N/A	N/A
Tube outlet for 44mm tube	N/A	TC1279-127D	N/A	N/A	N/A	N/A
2 x 32mm dia knockouts	N/A	N/A	N/A	TC1279-57B	N/A	N/A
2 x 46mm dia holes	N/A	N/A	N/A	TC1279-57C	N/A	N/A
					N/A	N/A

Adaptors

Lightpaths Adaptors are used to connect parts from other brands to the Lightpaths ducting~raceway.

Adaptor kit 100 x 100 lightpaths to ADC 4"	TC1279-109KIT
Adaptor kit Left hand lightpaths 220 x 100mm to ADC 6"	TC1279-149KIT
Adaptor kit Right hand lightpaths 220 x 100mm to ADC 6"	TC1279-150KIT
Speed Drop lightpaths to ADC	TC1279-307SLKIT
Adaptor kit lightpaths 300 x 100 to ADC 12"	TC1279-327KIT



Side Drop-off Kits

These components provide different methods of allowing fibers to enter or leave the duct - raceway. They can be purchased as kits or as individual.

Side drop off to 50mm dia. Convolved tube

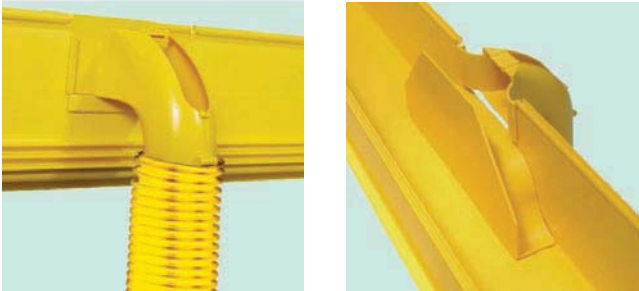

Use tool TC1279-50KIT to make cut-out in side of duct

TC1279-41KIT



- 1 x Drop off connector
- 1 x Spreader
- 1 x Ramp up

This drop can fit about 80, 2.4mm cables

Side drop off to 50mm square convoluted tube

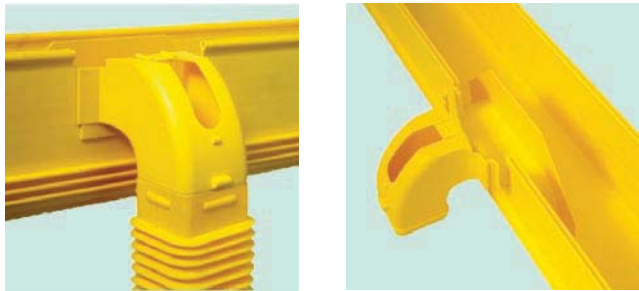

Use tool TC1279-50KIT to make cut-out in side of duct

TC1279-89KIT



- 1 x Drop off connector
- 1 x Spreader
- 1 x Ramp up

This drop can fit between 100 - 150, 2.4mm cables

Side drop-off to 50mm Ducting - Raceway



Use tool TC1279-50KIT to make cut-out in side of duct

TC1279-93KIT



- 1 x Break out
- 1 x Ramp up
- 1 x Joiner
- 1 x Down Elbow

This drop can fit between 100 - 150, 2.4mm cables

Side drop-off to 100 x 100mm Ducting-Raceway



Use tool TC1279-231KIT to make cut-out in side of duct

TC1279-111KIT



- 1 x Break out
- 1 x Joiner
- 1 x Down Elbow

This drop can fit between 500 - 600, 2.4mm cables

Side Drop-off Kits

Side drop-off to 100 x 50mm Ducting - Raceway

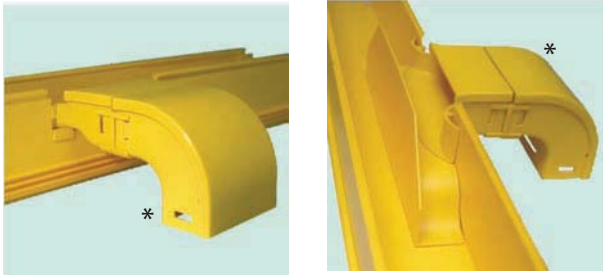

TC1279-232KIT

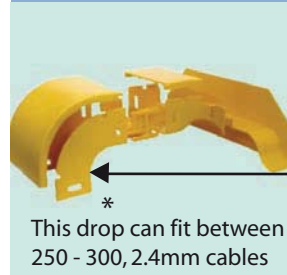

1 x Breakout
1 x Ramp Up
1 x Joiner
* Down Elbow not included in Kit.
Required separately
P/N TC1279-236A

Use tool TC1279-231KIT to make cut-out in side of duct

Top Outlet drop-off to 100 x 100mm Ducting - Raceway



Cut-out tool not required



Vertical Tees (Downspouts) See page 10



TC1279-63R

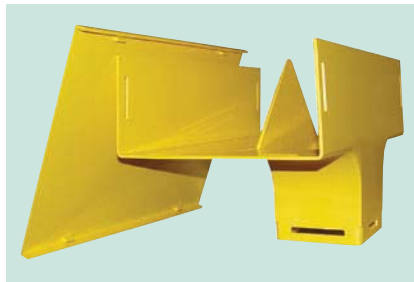

TC1279-11A



TC1279-11R

Drop Components



TC1279-212KIT
Radius guide
(Pack of 10) to suit 50
& 100mm slotted duct

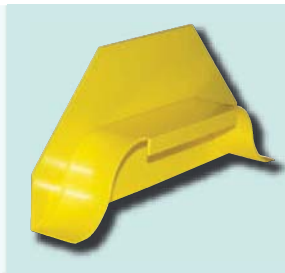

TC1279-42
Ramp Up



Outlet trumpet
TC1279-218A 100mm
TC1279-330A 220mm
TC1279-379A 300mm



TC1279-93A
Outlet trumpet
50 x 50mm



Top outlet
TC1279-290A



TC1279-307A
Top outlet



TC1279-290ASL
(With Slots)



TC1279-307ASL
(With Slots)

Reducers

Lightpaths Reducers allow different size ducts to be joined together. They are available with or without covers.

Main Size Reduction Size	50 x 50 30 x 30	100 x 50 50 x 50	100 x 100 50 x 50
Reducer	TC1279-97	TC1279-238	TC1279-91
Reducer & cover	TC1279-97A	TC1279-238A	TC1279-91A

Main Size Reduction Size	100 x 100 100 x 50	220 x 100 100 x 100	300 x 100 220 x 100
Reducer		TC1279-65	TC1279-281
Reducer & cover		TC1279-65A	TC1279-281A
Reducer Right Hand		TC1279-05	
Reducer Right Hand & Cover		TC1279-05A	
Reducer Left Hand		TC1279-07	
Reducer Left Hand & Cover		TC1279-07A	



Tubing

Lightpaths Tubing is used for feeding entering or exiting fibers from the ducting~raceway into equipment racks. They are convoluted or ribbed to allow adjustment if drops cannot be positioned exactly over or under equipment. Some are available with removable covers, or split for ease of cable installation.

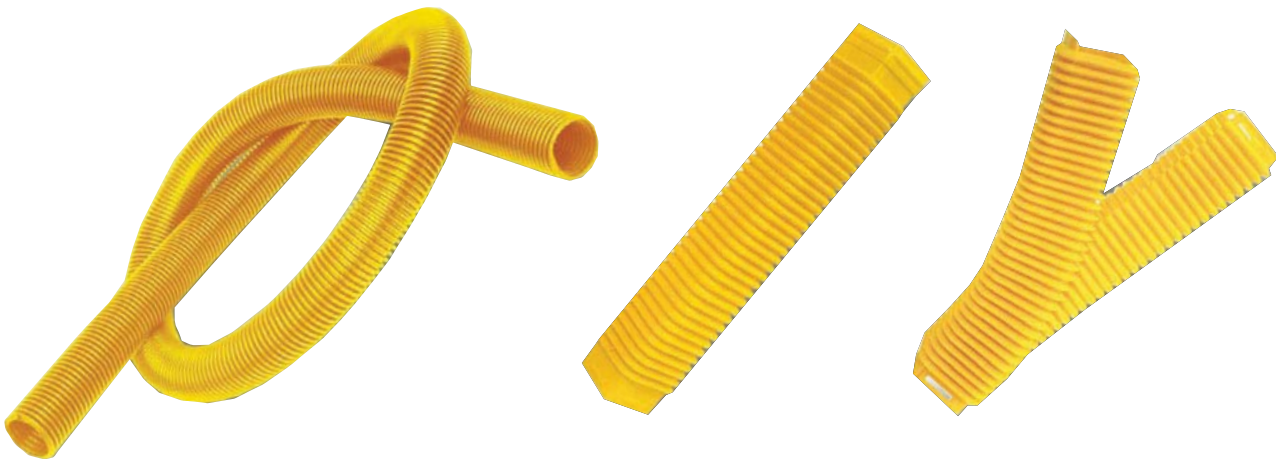

Description	Yellow	Black
Convoluted tube 50mm dia (1 meter length)	TC1279-26Y	TC1279-26
Convoluted tube 50mm dia (2 meter length)	TC1279-53Y	TC1279-53
Convoluted tube 25mm dia (2 meter length)	N/A	TC1279-54*
Convoluted tube 38mm dia (2 meter length)	N/A	TC1279-68
Convoluted tube 50mm square (350mm length)	TC1279-85YEL	TC1279-85BLK
Openable Conv. tube W/cover 50mm square (350mm length)	TC1279-85KIT	N/A *
Convoluted tube 30mm square (350mm length)	TC1279-88	N/A
Convoluted tube split 20mm dia (2 meter length)	N/A	TC1279-100
Convoluted tube with cover 50mm (1 meter length)	N/A	TC1279-350

*GREY

Mounting Hardware

Plastic Mountings

A new, strong but lightweight plastic mounting bracket system is now available. With an efficient one-suits-all approach the one system of plastic brackets can accommodate all sizes of ducting from 50mm to 300 mm. This revolutionary approach to ducting mounting allows for a large variety of configurations and eliminates the need for C brackets. Any excess bracket material is very easy to cut off. A further benefit of the plastic bracket is that it electronically insulates the raceway system from the wall and is available in all the same colours as Lightpaths Ducting - yellow, orange and black and Grey.

Suspension Mounting

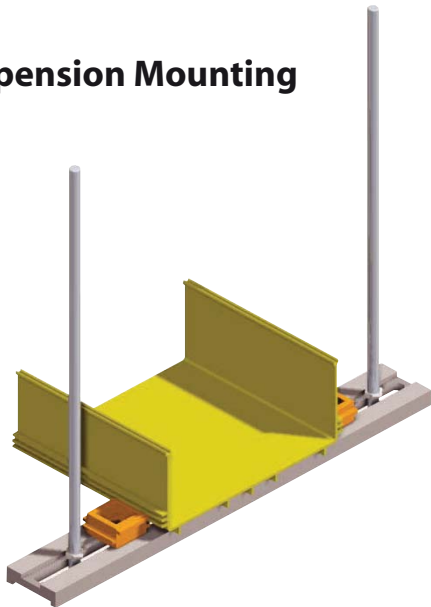

Wall Mount or Ladder Mount

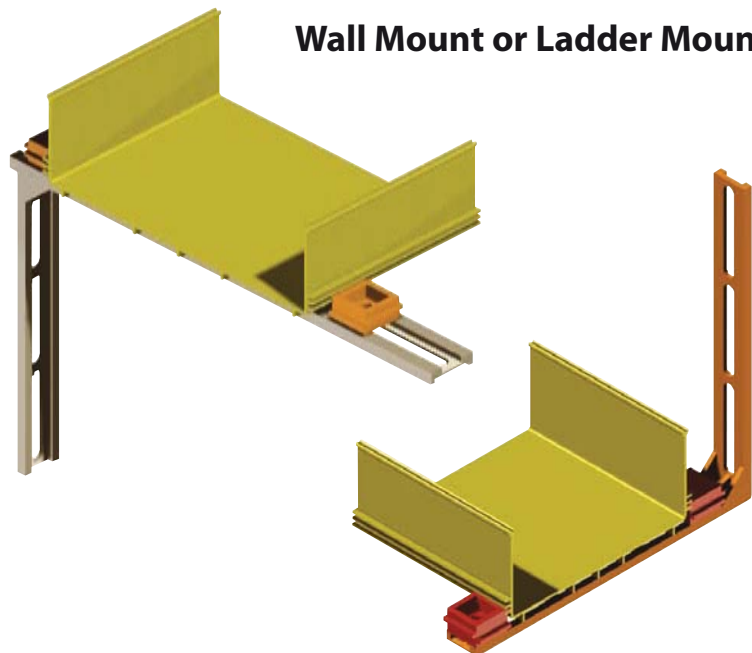

Mounting Hardware

Lightpaths mounting hardware is used to support the ducting~raceway from different structures. Although the most common components are shown here, many other components that have been developed for specific applications or customer requests are also available. Mounting Systems are also available for retro - fitting to existing installations. Custom components can also be manufactured to your specifications. Please contact your Lightpaths sales office or distributor for assistance.

Mounting Kits



TC1279-104KIT
 1 x Duct Mounting bracket 100mm
 1 x Right Angle bracket
 1 x Auxiliary base
 4 x Screws
 4 x Nuts
 9 x Washers
 1 x Hex Screw

TC1279-133KIT
 1 x Duct Mounting bracket 220mm
 1 x Right Angle bracket
 1 x Auxiliary base
 4 x Screws
 4 x Nuts
 9 x Washers
 1 x Hex Screw

Provides Vertical & Horizontal mounting flexibility to steel-work or walls



TC1279-161KIT
 1 x Right angle bracket
 1 x Support bracket
 4 x Screws
 8 x Washers
 4 x Nuts

 Kit provides extension to 260mm with 100mm duct mounting bracket

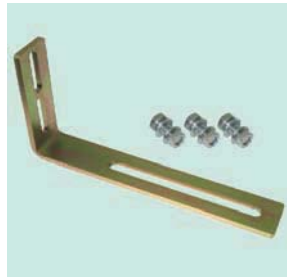

TC1279-183KIT
 1 x Right angle mounting bracket
 2 x Nuts
 3 x Screws
 3 x Washers

 Kit provides extension to 360mm with 220mm duct mounting bracket

Suspension Kits



TC1279-297AKIT
 1 x Duct Mounting bracket 300mm
 2 x Straight bracket
 2 x Threaded rod 12mm x 1M
 12 x Washers
 8 x Locknuts
 2 x Bolts
 2 x Screws

TC1279-297KIT
 1 x Duct mounting bracket 300mm
 2 x Straight brackets
 3 x Nuts
 3 x Bolts 1/2" x 13mm
 5 x Washers

 (no threaded rod)



TC1279-106KITA
 1 x Duct Mounting bracket 220mm
 1 x Straight bracket
 2 x Threaded rod 12mm x 400mm
 8 x Nuts
 1 x Bolt 12mm x 13mm
 9 x Washers
 TC1279-106KITB
 Contains 2 x 16mm threaded rod instead of 12mm

TC1279-107KITA
 1 x Duct Mounting bracket 100mm
 1 x Straight bracket
 2 x Threaded rod 12mm x 400mm
 8 x Nuts
 1 x Bolt 12mm x 13mm
 9 x Washers
 TC1279-107KITB
 Contains 2 x 16mm threaded rod instead of 12mm

Raised Mounting Kits

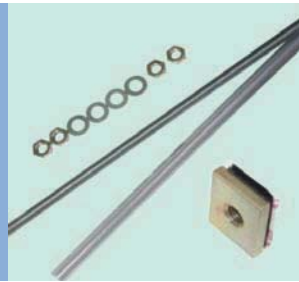

TC1279-129KIT

- 1 x Mounting Plate
30 - 50mm
- 1x 2 part Hook & Loop adhesive
- 1 x Treaded rod
12mm x 400mm
- 4 x Nuts
- 4 x Washers

TC1279-129KIT

This Mounting Kit is used for supporting 30 & 50 mm duct above or below cabinets or iron work.



TC1279-13A

- 1 x Duct mounting bracket 220mm
- 1 x Threaded rod
12mm x 400mm
- 3 x Nuts
- 3 x Washers
- 1 x Protective tube

TC1279-14A

- 1 x Duct mounting bracket 100mm
- 1 x Threaded rod
12mm x 400mm
- 3 x Nuts
- 3 x Washers
- 1 x Protective tube



TC1279-297BKIT

- 1 x Duct mounting bracket 300mm
- 2 x Straight bracket
- 2 x Threaded rod 5/8" UNC x 300mm
- 8 x Nuts 5/8"
- 2 x Nuts 1/2"
- 2 x Bolts 1/2" x 13mm
- 12 x Washers

TC1279-297BKIT

This Mounting Kit is used for supporting 300 mm duct above or below cabinets or iron work.

Underfloor Mounting Kits



TC1279-197KIT

- 1 x Bracket
- 1 x U-Bolt
- 2 x Nuts
- 1 x Flat bar washer

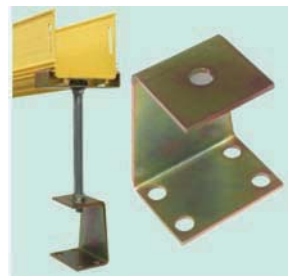

TC1279-274

- 1 x Bracket only

Used to support duct mounting kits from concrete floor in raised floor applications. Can be simply glued or bolted to the floor.

Ladder Rack and Unistrut Mounting Kits

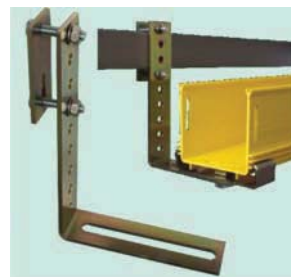

TC1279-155KIT

- 1 x Bracket
- 1 x Clamp Bracket
- 2 x Washers, Nuts & Bolts used with 100, 220, 300mm Duct mounting kits.



TC1279-171

- 1 x Bracket
- Used to attach 100, 200 & 300mm duct mounting kits from any 2" section

TC1279-154KIT

Used with 30 & 50mm Duct mounting kits.

TC1279-370KIT

Used with 100, 200, 300mm Duct mounting kits.

TC1279-59

- 1 X Bracket
- Used to attach 100, 200 & 300mm duct mounting kits from any 40mm section



Duct Mounting Brackets

- 30mm TC1279-148A
- 50mm TC1279-147A
- 100mm TC1279-16A
- 220mm TC1279-15A
- 300mm TC1279-297A



TC1279-78KIT

- 1 X Bracket with stud screw
- 1 x Hook & Loop adhesive pad(2 Parts)
- 2 x Bolts
- 3 x Nuts
- 3 x Washers



TC1279-130KIT

- 2 X Right angle bracket
- 1 x Bracket & stud
- 1 x Hook & Loop adhesive pad
- 3 x Bolts
- 4 x Nuts
- 5 x Washers



TC1279-303A

- 1 x Side mount bracket
- 1 x Bolt
- 1 x Washer
- Bracket provides side and height adjustment for 300, 220 & 100mm duct mounting brackets.

Tooling

Tool Kits and individual tools are available for cutting, slotting and providing cut-outs for drop components.



Tooling Components

Slotting tools are used to produce slots in the end of a cut length of duct required by the snap together of joiners.



Cut out tools are used to cut notches in the side of the duct to accommodate drop-outs. They are supplied with a fiber spreader to protect previously installed fibers when using the tools.



Mitre boxes are used to provide a means of producing an accurate and straight cut on ducting, essential for correct alignment of the slotting tools and joiners

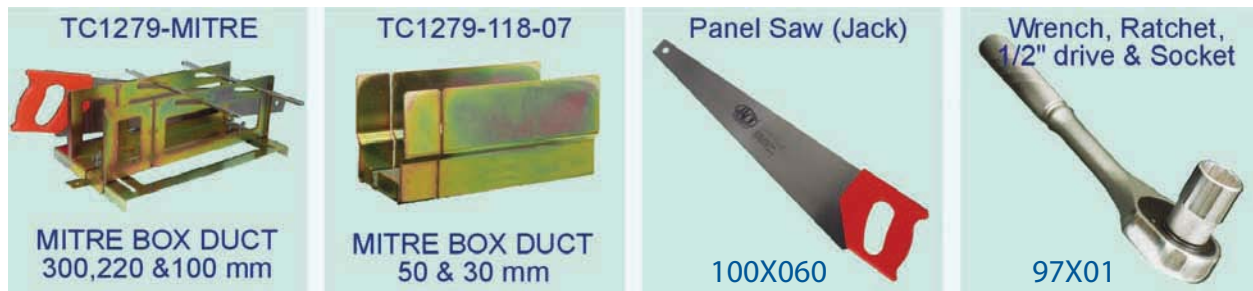

	TC1279-119KIT 30mm cut & slot kit	TC1279-118KIT 50mm cut & slot kit	TC1279-51KIT 100/220mm cut & slot kit
30/50mm mitre box	Yes	Yes	
100/220/300mm mitre box			Yes
Panel saw			Yes
Tool box	Yes	Yes	Yes
30mm slot tool	Yes		
50mm slot tool		Yes	
100/220mm slot tool			Yes
Fiber spreader			Yes

	TC1279-140KIT 30/50mm cut & slot kit	TC1279-50KIT 100/220mm cut & slot kit	TC1279-TKIT Combination Kit	TC1279-231KIT 30, 50, 100, 220 & 300mm cut out tool kit
30/50mm mitre box	Yes		Yes	
100/220/300mm mitre box			Yes	
Panel saw			Yes	
Tool box	Yes	Yes	Yes	Yes
30mm slot tool	Yes		Yes	
50mm slot tool	Yes		Yes	
100/220mm slot tool			Yes	
100x50mm side slot tool			Yes	
Cut-out tool		Yes	Yes	
Large cut-out tool - 100mm drop				Yes
Wrench		Yes	Yes	Yes
Fiber spreader		Yes	Yes	Yes

Useful Miscellaneous Items

**TC1279-294:
RAMP OFF FOR 300,
200, 100mm DUCT**

The ramp off is used in conjunction with the 100 x 50mm break out (Part No: TC1279-232A) to prevent stressing fibre by maintaining a safe bending radius for the fibers being dropped off or leaving: 300mm, 220mm or 100mm duct. It does this simply by providing a curved ramp up which fiber is able to form a 30mm radius.



**TC1279-156:
UNIVERSAL RADIUS GUIDE:**

This guide is used where pigtails and patch - cords are routed around 90-degree corners. It is a simple means of providing a 30-mm radius guide that eliminates fiber stress through bending.



Can be joined and clipped to sheet metal



**TC1279-57D:
END SUPPORT BRACKET FOR 100MM X 100MM DUCT**

The duct end bracket is used to fasten the open end of a standard 100mm straight duct to the top of a rack. It is fitted with double sided tape that secures and holds the end bracket to the rack. The end bracket simply snaps into the end duct slots.

**TC1279-72KIT:
PIGTAIL RADIUS GUIDE KIT**

The pigtail radius guide kit is used to ensure that fiber remains stress free when it is 'bent' around corners. One guide provides a 90 degree bend, but the guides are interlocking so that many can be joined to form U turns, circles & spirals - as required. (10 per kit)



GREY PVC SLOTTED DUCT-
This slotted duct is used for dropping off optical fibers from the overhead ducting system to racks & equipment sub-racks/panels.



- TC1279-55KIT:
50 X 50mm X 2MT**
- TC1279-58KIT:
25 X 30mm X 2MT**
- TC1279-99KIT:
60 X 40mm X 2MT
(not slotted)**

Other Warren & Brown Products

**Splice / Patch Modules
Swing out Trays
Fiber Storage Units**



Splice Trays



Termination Racks



We also supply pigtails / patchcords, couplers, splitters, thru adaptors, etc. As well as many other components Warren & Brown also do duct layouts, planning and installations and are we are happy to provide a free quotation.

APC	Angled Physical Contact. Connector designed with an 8 deg angle at the end of the ferrule.
BER	Bit Error Rate.
Buffered Fiber	An un-jacketed cable. It consists of a coated fiber surrounded by a 900 micron diameter buffer.
Cladding	The lower refractive index material that surrounds the fiber core and provides optical insulation and protection.
Cleave	The controlled breaking of a fiber so that its surface is smooth.
Connector	A mechanical device used to join fibers together.
Coupler	A mechanical device used to couple light from one fiber optic cable into another.
dB	The abbreviation for decibel, which is the standard unit used to express signal gain or loss. A measure of the frequency dependence in transmittance.
Dispersion	Two major types of dispersion are modal and material. Can be caused by multiple frequency components having different propagation characteristics, or the relationship between the refractive index and wavelength or frequency. One of the limits on bandwidth.
Dispersion Shifted Fiber	A single mode fiber that has zero dispersion wavelength at 1550 nanometres.
Dispersion Unshifted Fiber	A single mode fiber that has zero dispersion wavelength at 1300 nanometres. Often called conventional or unshifted fiber.
Duplex Cable	Cable with two fibers.
Ferule	A component with precise capillary which holds a fiber in place and aids its alignment. The typical ferule has an OD of 2.5mm and a capillary of about 125 microns. Single mode versions normally carry tolerances of one micron or less.
Fiber	A single, separate optical transmission element characterised by a core and a cladding, with an outside diameter of 125 microns.
Fresnel Reflection	The reflection of light from an optical discontinuity.
Fusion Splicing	The joining of two fibers by heating and fusing them together.
GHz	GHzGigahertz. One billion hertz.
Gigabit	Transmission of one billion bits per second, Gbps.
Hertz (Hz)	A measure of frequency as defined in units of cycles per second.
Index of Refraction	The ration between the speed of light in a vacuum and the speed of light in a referenced medium.
Index Matching Material	A material, usually a liquid, gel, paste or film, whose index of refraction matches the glass used for the fiber. It is used at the end face of the fiber to reduce Fresnel reflections.
Insertion Loss	The attenuation (loss) of power at a connector interface, expressed in dB.
Jacket (Sheath)	The outermost segment of a fiber optic cable, generally a plastic material.
Jacketed Cable	Buffered fiber protected with a strength member such as Kevlar, and an outer jacket.
Kilometre	One thousand metres (3,281 feet).
Laser	Light Amplification by Stimulated Emission of Radiation. A device that produces coherent light with a narrow range of wavelengths.
Loose Tube	A protective polymer tube, often filled with a gel, used to contain one or more fibers.
Metre	A metric unit of measure that equals 39.37 inches.
Mhz	Megahertz, one million hertz.
Microbending Loss	Loss due to microscopic bends in the fiber.
Micrometre	One millionth of a metre, equivalent to 39.37 micro-inches also called Micron (um).
Multiplexing	The combination of two or more signals from two or more channels into a single output.
Nanometre	One billionth of a metre, equivalent to 0.039 micro-inches.
OTDR	Optical Tim Domain Reflectometer. A device that measures distance to a reflective surface by measuring the time it takes for a lightwave pulse to reflect from that surface.
PC	Physical Contact. The term used to describe connectors that allows the ends of the fiber to make contact (with an adaptor).
Patchcord	A length of cable with a connector at each end.
Pigtail	A length of cable with a connector at one end only.
Reflection	The abrupt change in direction of a light beam at an interface between two dissimilar media, so that the light beam returns into the medium from which it originated.
Refraction	The bending of a beam of light through an interface between two.
Return Loss	Same as reflection except the sign of the wave is positive. The amount of power reflected back into the source. The greater the return loss the better the performance. Expressed in dB.
SC connector	A plastic, rectangular connector body with a 2.5 millimeter diameter ceramic ferrule. The connector utilizes a push/pull "snap in" concept.
Simplex cable	Cable with only one fiber.
Singlemode	Optical fiber designed to propagate only one mode. Components associated with this type of fiber require much tighter alignment tolerances than multimode fiber and as a result are more expensive.
Source	A light emitting diode or laser diode that emits optical signale into the fiber network in response to an electrical signal input.
Splice, Fusion	Permanent joining of fiber ends by heating and fusing them together.
Splice, Mechanical	The joining of two fibers by a mechanical method (clamped, crimped or epoxied).
Splitter	Also known as a coupler.
ST Connector	A metal or plastic connector with a 2.5 millimeter diameter ferrule. The connector features a bayonet style, twist lock coupling method.
Through Adaptor	Used to connect or join two connectors.
Transceiver	A device that combines both functions of the transmitter and receiver, thereby providing both output and input interfaces.
Wavelength	The distance that a wave travels in the time it takes to oscillate through a complete cycle.

YELLOW DUCT.COM

Europe and the Middle East



www.mulder-hardenberg.com

Mulder-Hardenberg B.V.
Westerhoutpark 1a
2012 JL Haarlem
The Netherlands
Tel.: +31-23 531 91 84
E-mail: infol@mulder-hardenberg.com

Mulder-Hardenberg N.V.
Hoge Weg 129
B-2940 Stabroek
Belgium
Tel.: +32 (0)3 660 13 20
E-mail: info@mulder-hardenberg.com

Mulder-Hardenberg GmbH
Nordring 13
D-65719 Hofheim/Ts
Tel. +49 (0)6192 - 97 91 85
E-mail: info@mulder-hardenberg.com

Australian and Far East



www.warrenandbrown.com.au

Warren & Brown Technologies
108 Mitchell Street,
Maidstone, Victoria 3012
Phone: (613) 9318 5844
Email: Sales@warrenandbrown.com.au